

ORDERING INFORMATION:

FLOW SENSOR TYPE

- TR 101 : Threaded
- TR 102 : Threaded SMART

FLOW SENSOR SIZE

- DN 25 : 1"
- DN 32 : 1 1/4"
- DN 40 : 1 1/2"
- DN 50 : 2"
- DN 65 : 2 1/2"

FLOW TRANSMITTER

- MFT 01 : Mag Flow Transmitter
- SJ 1101 : SMART Jal-oagh Transmitter

MOUNTING

- FT01 : Integral
- FT02 : Remote-Wall
- FT03 : Remote-Pipe

POWER SUPPLY

- 01 : 110 V AC \pm 10%, 50 /60 Hz
- 02 : 230 V AC \pm 10%, 50 /60 Hz
- 03 : *85 V AC to 265 V AC, 50/60 Hz

TR 101 DN 40 MFT01 FT01 02 Sample Order Code

Note : Threaded style flowmeter is available only from line size DN 25 to DN 65 with rubber lining.

* This Power Supply option is applicable only to SJ-1101.

FLOW SENSOR TYPE

- WA 301 : Wafer-Rubber
- WA 302 : Wafer-PTFE
- WA 303 : Wafer-Rubber-SMART
- WA 304 : Wafer-PTFE-SMART

FLOW SENSOR SIZE

- DN 50 : 2"
- DN 65 : 2 1/2"
- DN 80 : 3"
- DN 100 : 4"
- DN 125 : 5"
- DN 150 : 6"
- DN 200 : 8"

ELECTRODE MATERIAL

- EM 01 : Stainless Steel 316
- EM 02 : Hastelloy C
- EM 03 : Any Other

BODY MATERIAL

- CS : Carbon Steel
- SS 304 : Stainless Steel 304
- SS 316 : Stainless Steel 316

FLOW TRANSMITTER

- MFT- 01 : Mag Flow Transmitter
- SJ -1101 : SMART Jal-oagh Transmitter

MOUNTING

- FT 01 : Integral
- FT 02 : Remote-Wall
- FT 03 : Remote-Pipe

POWER SUPPLY

- 01 : 110 V AC \pm 10%, 50/60 Hz
- 02 : 230 V AC \pm 10%, 50 /60 Hz
- 03 : *85 V AC to 265 V AC, 50/60 Hz

WA 301 DN 100 EM 01 CS SJ-1101 FT 01 02 Sample Order Code

Note: Wafer Style flowmeter is available from line size DN 50 to DN 200.

*This Power Supply option is applicable only to SJ-1101.

Due to continuous development specifications are subject to change without prior notice.

manas microsystems pvt. ltd.

REGD. OFFICE : ROW HOUSE NO. 5, PARVATI PARK, DATTAWADI, PUNE 411 030
 WORKS : EL 54 ELECTRONIC ZONE, M.I.D.C. BHOSARI, PUNE 411 026. (INDIA)
 TEL. : 020-27127044,27127047, 27127858 FAX : 020-27127045
 E-MAIL : E-MAIL: mktg@manasmicro.com WEBSITE : www.manasmicro.com



Catalog No.: Fc-FBE-06

Crownsnp @ vsnl.com nov 2009-2000

manas

.... a name that spells trust
 AN ISO 9001:2000 COMPANY

We Measure Flow

JAL-OAGH

Most Trusted Product with CE Certification



INTRODUCTION :

- ◆ Know your water consumption
- ◆ Not just by assumption,
- ◆ But by correct instrumentation.
- ◆ Jal-oagh provides the solution.

MANAS has introduced a new economical series of E.M.F., considering water as the most important utility in any industry.

JAL-OAGH 100, 300 SERIES OF EMF

These flow meters are dedicated for waste water management system, sewage & effluent water measurement. These flow meters are mainly categorized into two i.e. Threaded & Wafer type. Threaded is available from DN 25 to DN 65 i.e. Jal-oagh 100 Series while Wafer is available from DN 50 to DN 200 i.e. Jal-oagh 300 Series.

Principle of Operation :

The JAL-OAGH series of electromagnetic flow meters work on FARADAY'S LAW OF ELECTROMAGNETIC INDUCTION. When a conductor moves within a magnetic field, voltage is induced in it which is proportional to the velocity of the conductor.

In this case the conductor is flowing media. The equation is as below:

$$E = B.v.d$$

Where

E = Induced voltage [proportional to velocity]

B = Magnetic flux density

v = Mean velocity of the media

d = distance between the sensing electrodes

For a given size of flow tube & compatible amplifier the flux density 'B' is constant, the distance between the electrodes is constant. Hence, the induced voltage is proportional to the velocity of the flowing media. Thus the unit can be calibrated in terms of volumetric flow rate by knowing the cross-sectional area of the tube.

Principal advantages of JAL-OAGH :

- 1) Small in size, Light in weight compared to other magnetic meters in its class
- 2) Full bore electromagnetic flow meter with absolutely no restriction to flow
- 3) Has a typical accuracy of $\pm 0.5\%$.
- 4) Measurement is independent of the velocity profile across the pipe
- 5) Measurement results are independent of density, viscosity, pressure, temperature, solid impurities and conductivity variations (above $5\mu S/cm$ for MFT-01 & above $20\mu S/cm$ for (SMART JAL-OAGH)

TYPICAL ERROR DIAGRAM

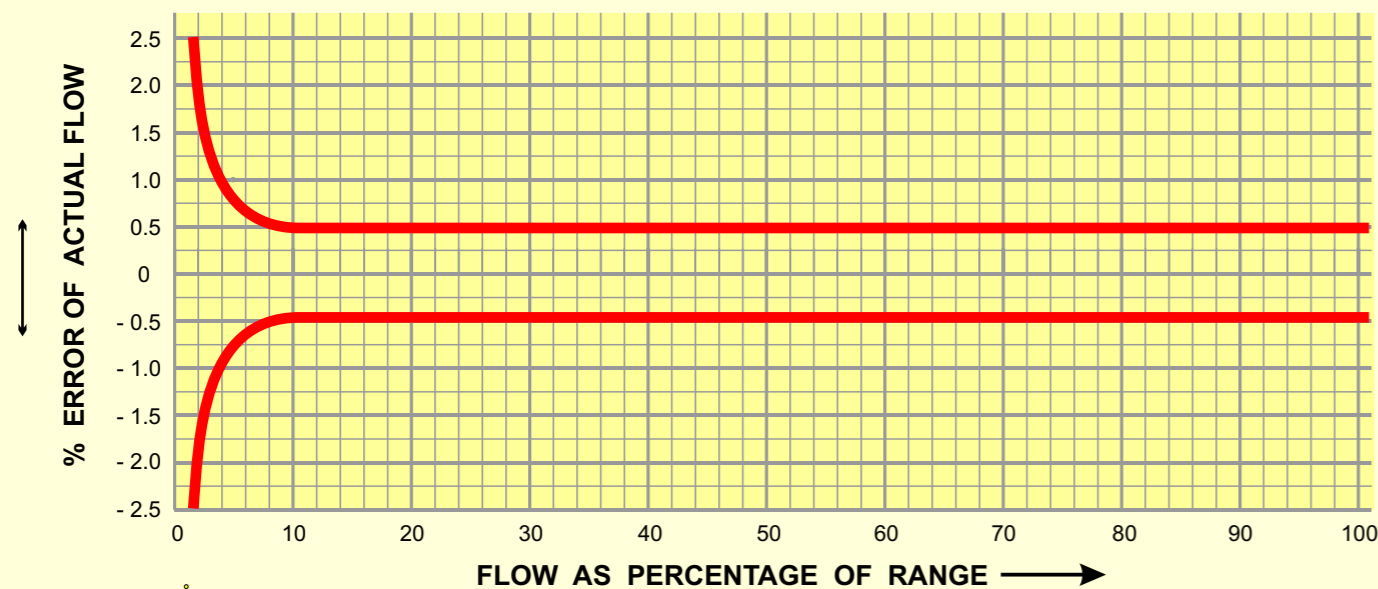

- 6) Fits in between the flanges of the pipe which makes it the most compact solution for flow measurement.
- 7) Compatible virtually with all corrosive and non-corrosive liquids.
- 8) It is a very cost-effective and economical flow meter as compared to other flow meters in its class.

JAL-OAGH APPLICATION :

1. Effluent Treatment :
Untreated as well as Treated Effluent Water Measurement.
2. Sewage Treatment :
Waste water measurement, Sludge measurement etc.
3. Water Supply Schemes :
Raw water as well as treated water measurement.
4. Boiler Feed Water Measurement.
5. Chemical Industries :
Measurement of acidic & alkaline chemicals & slurries.

ELECTROMAGNETIC FLOW METER (FULL BORE)

SPECIFICATIONS :

PRIMARY FLOW TUBE : JAL-OAGH

1. Metering tube : Jal-oagh 101 (Threaded-Rubber)
Jal-oagh 102 (Threaded-Rubber-SMART)
Jal-oagh 301 (Wafer-Rubber)
Jal-oagh 302 (Wafer-PTFE)
Jal-oagh 303 (Wafer-Rubber-SMART)
Jal-oagh 304 (Wafer-PTFE-SMART)
2. Meter Size : DN 25-DN 65 (Threaded)
DN 50-DN 200 (Wafer)
3. Media Pressure : Upto DN 80 - PN - 40
From DN 100 - DN 150 - PN - 16
DN 200 - PN 10
4. Media Temperature : Rubber Liner 0-90°C max
PTFE Liner 0-150°C max
5. Operating Temperature Range : 0-50°C
6. Material of Construction : a) Flow Tube: SS 304 (non-magnetic)
b) Electrodes: SS 316, Hastelloy C
c) Liner: Ebonite, PTFE
d) Body material: SS 304 / C.S.
7. End Connections : Threaded: BSP/NPT (M)
Wafer: DN 50 - DN 150 Meter to be sandwiched between Two ANSI 150 class Flanges.
DN 200 Meter to be sandwiched between two BS10 Table F Flanges.
8. Power Supply to field coils : Pulsed D.C.

SPECIFICATIONS OF FLOW TRANSMITTER

MANAS provides 2 different types of transmitters MFT- 01 or SJ-1101.

A) JAL-OAGH MFT-01

1. Mounting : Integral / Remote Mounting
2. Min Media Conductivity : Greater than $5\mu S/cm$
3. Input : Micro-volt Signal proportional to flow rate from primary Flow sensor.
4. Signal Output : i) 4-20mA DC isolated in max 600 prop. to 0-100% of flow rate
ii) Pulsed output with adjustable count rate from 1 count/Hr to 10^5 counts/ Hr (Open collector with 30 mA/ 24 V DC capacity). (Optional)
5. Local Display : i) $3\frac{1}{2}$ digit, 0.5" LCD calibrated in % or engineering units
ii) 8 digit LCD non-resettable type for totalized quantity
6. Ranges : 4 fixed ranges i) 1.25 ii) 2.50 iii) 5.00 iv) 10.00 m/s FS
7. Flow Velocity Range : 0.1 m/s to 10 m/s
8. Accuracy : Maximum Inaccuracy 1% of reading between 100% to 10% of calibrated flow range.
9. Repeatability : 0.2% of reading
10. Operating Temperature : 0-50 °C
11. Temperature Drift : 0.015% per °C
12. Material of Housing : Al Die Cast
13. Power Supply : 230VAC/ 110VAC, 50 Hz
14. Cable Entries : 4 nos for remote transmitter.
2 nos for integral transmitter.
PG 11/ $\frac{1}{2}$ " NPT/ $\frac{1}{2}$ " BSP
15. Ingress Protection : IP-65

B) SMART JAL-OAGH (SJ-1101)

1. Mounting : Integral / Remote Mounting - Wall Mounting / 2" Pipe Mounting
2. Min Media Conductivity : Greater than $20\mu S/cm$
3. Input : 1. Micro-volt signal prop. to flow rate from Primary flow sensor
2. Empty Tube signal from primary flow sensor
4. Signal Output (Optional) : i) 4- 20 mA dc (Isolated) in max. 600 Ohms prop. to 0 -100 % flow rate.
ii) Pulsed output with adjustable count rate from 1 count/Hr to 10^5 counts/ Hr (Open collector with 30 mA/ 24 V DC capacity). (Optional)
5. Local Display : 16 characters x 2 rows LCD Display for Instantaneous Flow Rate, Totaliser, Engineering Units, Fault messages.
6. Ranges : 4 fixed ranges i) 1.25 ii) 2.50 iii) 5.00 iv) 10.00 m/s FS
7. Flow Velocity Range : 0.1 m/s to 10 m/s
8. Accuracy : Maximum Inaccuracy 1% of reading between 100% to 10% of calibrated flow range.
9. Repeatability : 0.2% of reading
10. Operating Temperature : 0- 50°C
11. Temperature Drift : 0.015% per °C
12. Material of Housing : Al Die cast
13. Power Supply : 85 V AC to 265 V AC, 50 HZ
14. Cable Entries : 4 nos for remote transmitter.
2 nos for integral transmitter.
PG 11
15. Ingress Protection : IP-65
16. Keyboard : 4 Number of Keys for Parameter Programming
17. COMM PORT [Optional] : RS232 / RS485 [Protocol MODBUS RTU]

FLOW RATE TABLE

Flow Rate at v = 1 m/s

DN	m3/hr	LPM	LPS	DN	m3/hr	LPM	LPS
25	1.767	29.452	0.490	80	18.095	301.592	5.026
32	2.895	48.254	0.804	100	28.274	471.238	7.853
40	4.523	75.398	1.256	125	44.178	736.310	12.271
50	7.068	117.809	1.963	150	63.617	1060.287	17.671
65	11.945	199.098	3.318	200	113.097	1884.955	31.415

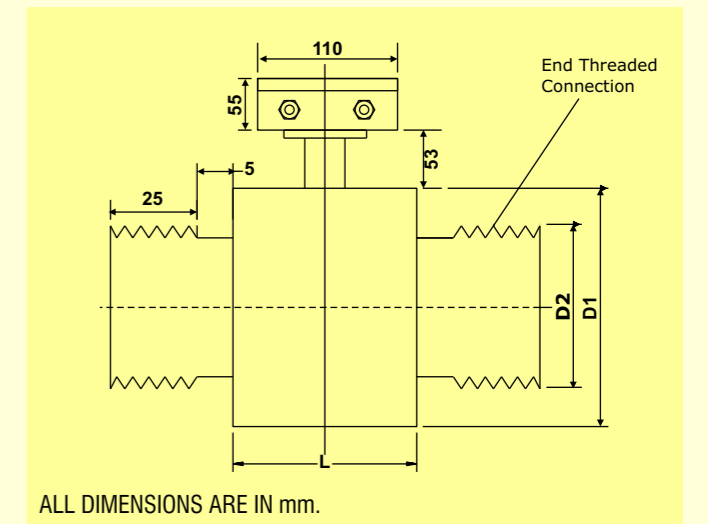

ALL DIMENSIONS ARE IN mm.

MTR Size	D1	D2	L	BSP/NPT
DN 25	66	24.3	76	1"
DN 32	75	32.5	76	1.25"
DN 40	85	38.1	76	1.5"
DN 50	104	49.25	76	2"
DN 65	123	59.0	102	2.5"

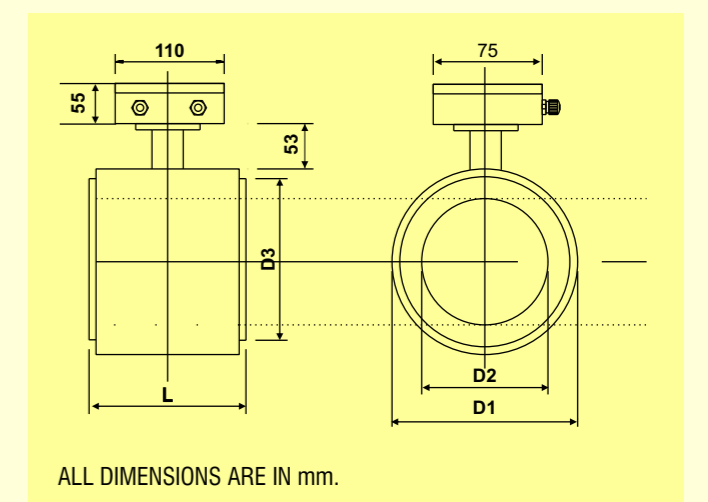

ALL DIMENSIONS ARE IN mm.

MTR Size	D1	D2	D3	L
DN 50	104	43.5	92.0	107
DN 65	123	53.5	105.0	128
DN 80	136	69.0	127.0	128
DN 100	174	93.5	157.0	160
DN 125	196	118.0	186.0	160
DN 150	222	144.0	216.0	160
DN 200	305	192.0	285.0	220