

Meter Dimensions (mm)

DN(mm)	A	B	C	D	E
10, 15, 20,	60	180	115	200	76
25, 32,	80	197	150	200	96
40, 50,	115	232	220	200	102
65, 80,	122	239	233	200	102
100,125,	170	287	330	250	132
150	180	297	350	300	172
200	235	352	460	350	207
250	290	407	570	400	242
300	335	452	660	500	292
350	355	467	690	550	292

Dimensions are with ANSI 150 Flanges, with terminal box.  
(for other flange rating consult factory)  
Dimension 'D' is without earthing rings.  
Standard flanges ANSI150 up to DN 150  
B510, Table F : DN 200 & onwards.

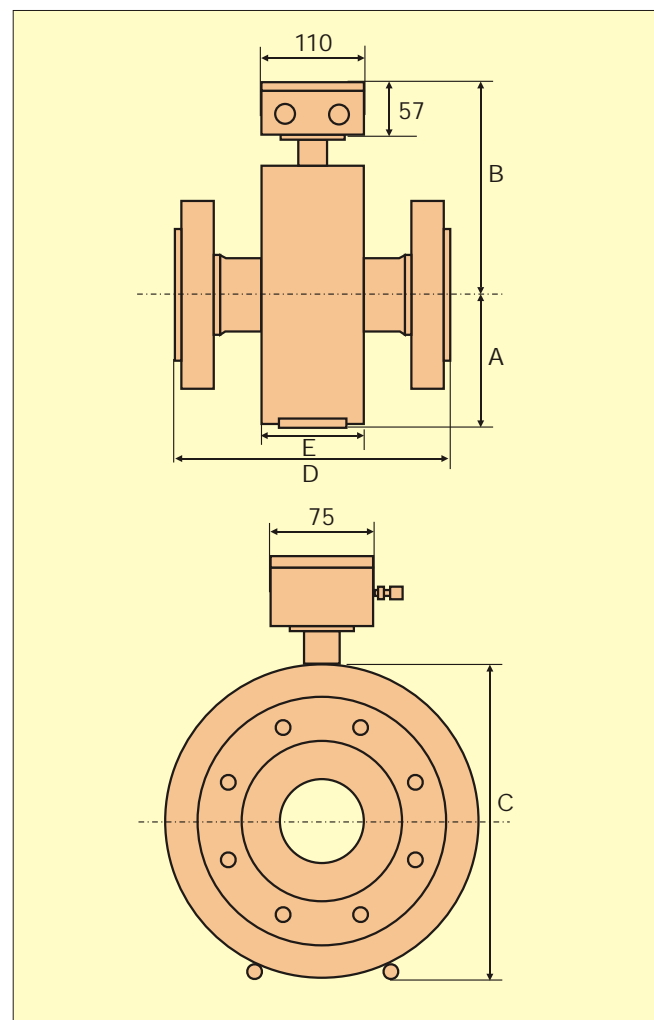

ORDERING INFORMATION

Flow Meter Size	
MS 01 : DN 10	MS 09 : DN 80
MS 02 : DN 15	MS 10 : DN 100
MS 03 : DN 20	MS 11 : DN 125
MS 04 : DN 25	MS 12 : DN 150
MS 05 : DN 32	MS 13 : DN 200
MS 06 : DN 40	MS 14 : DN 250
MS 07 : DN 50	MS 15 : DN 300
MS 08 : DN 65	MS 16 : DN 350

Liner Material
LM 01 : Teflon(PTFE)
LM 02 : Neoprene
LM 03 : Soft Rubber
LM 04 : Hard Rubber
LM 05 : Any other

Electrode Material
EM 01 : Stainless Steel 316
EM 02 : Hastelloy C
EM 03 : Tantalum
EM 04 : Titanium
EM 05 : Platinum
Em 06 : Any other

Flange/End Connection Standards
FS 01 : DIN PN 40
FS 02 : DIN PN 16
FS 03 : DIN PN 10
FS 04 : ANSI 300
FS 05 : ANSI 150
FS 06 : SMS
FS 07 : Tri-clamp
FS 08 : Any other

Flange /End Connection Material
FM 01 : Carbon Steel
FM 02 : Stainless Steel 304
FM 03 : Stainless Steel 316
FM 04 : Stainless Steel 316L

Flow Transmitter
FT 01 : Integral [Al. Diecast]
FT 02 : Remote [Al. Diecast]

Power Supply
01 : 110 ± 10% V AC, 50Hz
02 : 230 ± 10% V AC, 50Hz
03 : 24 Vdc ± 10 %

MS 03 LM 01 EM 02 FS 05 FM 01 FT 02 01 Sample Order Code

Due to continuous development specifications are subject to change without prior notice.

manas microsystems pvt. ltd.

REGD. OFFICE : ROW HOUSE NO. 5, PARVATI PARK, DATTAWADI, PUNE 411 030  
WORKS : EL 54 ELECTRONIC ZONE, M.I.D.C. BHOSARI, PUNE 411 026. (INDIA)  
TEL. : 020-27127044,27127047,27127858 FAX : 020-27127045 E-MAIL : manasmicro@vsnl.com



manas



We Measure Flow



MAGMETER

Sroat - 1000

Stable Repeatable Operable Accurate Technique

## MAGNETIC FLOW METER SROAT -1000

### INTRODUCTION :

The Manas Make electromagnetic flow meter called as SROAT-1000 virtually approaches the ideal flow meter suitable for wide range of liquid flow measurements even with very low conductivities. The meter offers no resistance to flow hence the pressure drop is almost negligible. The measurement being based on Faraday's law of electromagnetic induction, is independent of viscosity, density, pressure & temperature of flowing medium. The measurement is not affected by solid impurities as long as the min. conductivity of 5µs/cm is available. It is a true volumetric flow measurement. We offer various materials of construction for meter lining & electrodes to cover majority of corrosive liquids.

The technique called as " Pulsed DC " is used which offers very high Zero stability & accuracy of measurement.. The standard current output of 4-20 mA DC is provided which is linearly proportional to volumetric flow rate & additional frequency output is also provided.

### PRINCIPLE OF OPERATION:

The method of flow measurement is based on Faraday's law of electromagnetic induction. When a conductor moves within a magnetic field, voltage is induced in it which is proportional to the velocity of conductor.

In this case the conductor is flowing media. The equation is as below.

$$E = B.v.d$$

where,

E = Induced voltage [ proportional to velocity ]

B = Magnetic flux density.

v = Mean velocity of the media

d = Distance between the sensing electrodes

For a given size of flow tube & compatible amplifier the flux density 'B' is constant, the distance between the electrodes is constant. Hence, the induced voltage is proportional to the velocity of the flowing media. Thus, the unit can be calibrated in terms of volumetric flow rate by knowing the cross-sectional area of the Tube.

### PRINCIPAL ADVANTAGES :

1. Use of pulsed DC magnetisation & auto zero technique offers excellent long term zero stability.
2. Measurement is independent of velocity profile across the diameter of the pipe-line.
3. Measurement results are independent of density, viscosity, pressure, temperature, solid - impurities & conductivity variations [above 5µsiemens].
4. No additional pressure drop across the meter which relieves the process designer while sizing his pumping requirements. Simple to install as no special precautions of straight pipe lengths required.
5. Compatible with virtually all corrosive / non-corrosive liquids.
6. Protection class offered IP 65.
7. Reasonably higher ratio of Return on Investment to Investment.
8. Bath-Tub curve remains flatter for very long periods.

### APPLICATIONS :

This meter is more suitable with those fluids which present difficulties in handling. Fluids such as effluents, slurries, pulps, brines & other highly corrosive liquids, acids & bases, fermenter-wash, molasses etc.

Following industries can find lot of application of this flow measurement technique.

- Effluent Treatment Plants
- Sewage Treatment Plants.
- Water Supply Schemes.
- Steel & Aluminium.
- Sugar Industries & Distilleries.
- Pulp & Paper.
- Chemical / Pharmaceutical.
- Petrochemicals / Fertilizers.
- Food & Drugs.

## MAGNETIC FLOW-METER

### SPECIFICATIONS

#### METERING TUBE : SROAT 1000

1. Meter Size : DN 10 to DN 350  
for higher sizes consult factory
2. Media Pressure : Upto DN 80 - PN 40  
From DN-100 to DN 200 - PN 16  
DN-250 to DN 350 - PN 10
3. Media Temperature : PTFE Liner 0 - 150°C max. for  
other Liners 0 - 90°C max.
4. Ambient Temperature Range : 0 - 50°C
5. Materials : Pipe : SS 316 [non-magnetic ]  
Electrode : SS 316 / Hastelloy C / Pt /Ta /Ti.  
Liner : PTFE / Neoprene /Soft Rubber /  
Hard Rubber.  
Flanges : Carbon Steel / SS 316 / SS 316 L /  
SS 304.  
Coil Housing : Carbon Steel / SS, Epoxy Painted.
6. Flange Standard : ANSI / DIN /BS / SMS / Triclamp
7. Power Supply to field coils : Pulsed DC

#### TRANSMITTER SROAT 1000 A

1. Type : Integral mounted [standard]  
Remote Mounted [on request]
2. Min. Media Conductivity : 5 µs /cm [for lower conductivities  
consult factory]
3. Signal Output : 4-20 mA dc isolated in max. 600 ohms  
Additional option : Pulsed Output With adjustable count  
rate from 1 count / Hr to 10<sup>5</sup> Counts/ Hr.  
[Open collector with 100 mA/24 V dc  
capacity]

3. Signal Output (cont.)  
Or  
Frequency Output : 0-10 KHz prop. To 0 - 100% flow rate  
[open collector with 10 mA /24 v dc  
max.]
4. Coil Excitation Frequency : Selectable by DIP switch.  
a) 25Hz  
B) 12.5 Hz  
c) 6.25 Hz  
d) 3.125 Hz
5. Local Display : a) 3 ½ digit LCD calibrated in % or  
engineering units  
b) 8 digit LCD non resettable type  
for totalised quantity.
6. Flow Velocity Range : 0.1 m/s to 10 m/s
7. Accuracy : ±0.5% of reading [at ref. conditions]  
between 100% to 10% of calibrated  
range  
±0.75% of reading for flow rate  
between 10% to 5%  
[refer accuracy graph ]
8. Ref. Conditions : Power supply nominal.  
Temperature 27°C ± 2°C
9. Repeatability : ±0.2% of reading
10. Ambient Temperature : 0 - 50°C
11. Temperature Drift : ±0.015% per °C max.
12. Humidity : 90 % R. H. max. non condensing
13. Material of Housing : Al. Die cast.
14. Power Supply : 230 v ac/ 110 v ac 50 Hz/24 Vdc.
15. Damping : Adjustable from 5 to 30 Secs.
16. Cable Entries : 4 no. For remote amplifier  
2 no. For integral amplifier  
½" NPT / ½" BSP / PG11 [Female]
17. Ingress Protection : IP-65

### FLOW RATE TABLE : Flow rate at v = 1m/s

DN	M3/Hr.	LPM	LPS	DN	M3/Hr.	LPM	LPS
10	0.282	4.712	0.078	80	18.095	301.592	5.026
15	0.636	10.602	0.176	100	28.274	471.238	7.853
20	1.130	18.849	0.314	125	44.178	736.310	12.271
25	1.767	29.452	0.490	150	63.617	1060.287	17.671
32	2.895	48.254	0.804	200	113.097	1884.955	31.415
40	4.523	75.398	1.256	250	176.714	2945.243	49.087
50	7.068	117.809	1.963	300	254.469	4241.150	70.685
65	11.945	199.098	3.318	350	346.356	5772.608	96.210

### ERROR DIAGRAM

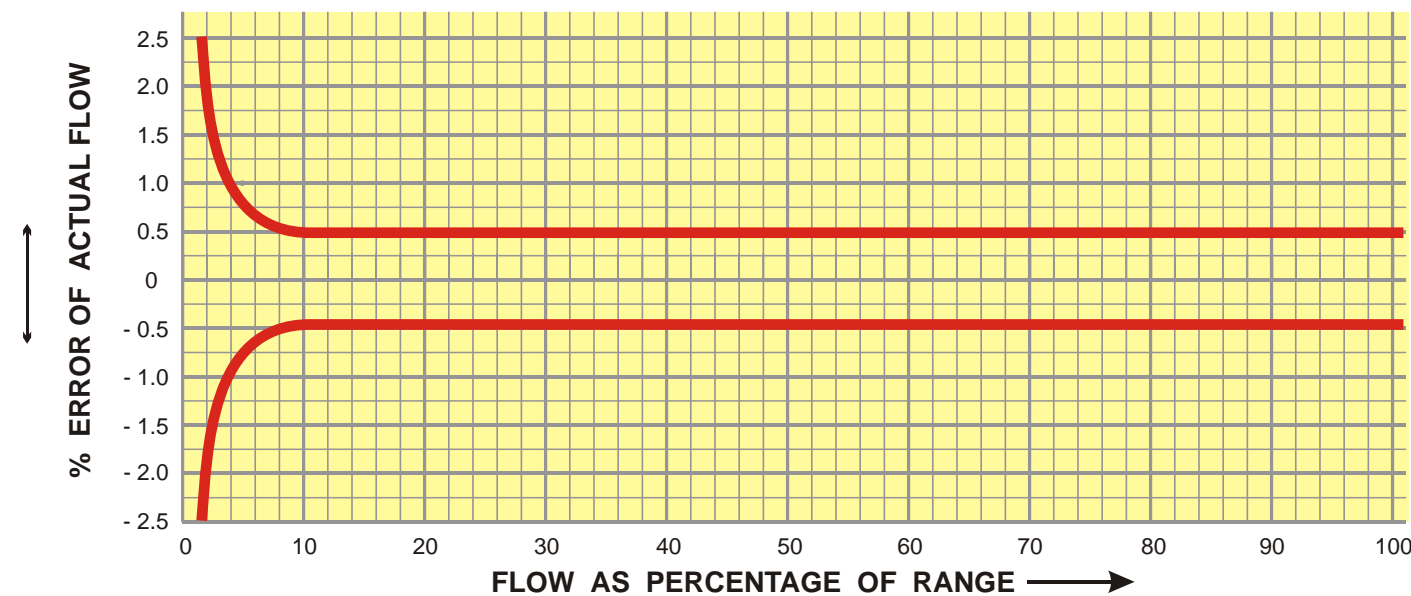

### Flow Nomograph

